

1940nm Polarization Maintaining Isolator

Key Features

- Low Insertion Loss
- High Extinction Ratio
- High isolation
- Excellent stability and reliability

The Polarization Maintaining Isolator is a two port micro-optic device built with PM panda fiber. The PM isolator features low insertion loss, high isolation, high extinction ratio and high reliability and stability. The device guides optical light in one direction and eliminates back reflection and back scattering in the reverse direction. The device can be built with bare fiber, or 900um jacket cable. The PM Panda Fiber Isolator is widely used in amplifier systems, fiber optic systems and fiber lasers .

If you do not see a standard isolator that meets your needs, we welcome the opportunity to review your desired specification and quote a custom isolator. Requests for custom fiber pigtailed, different wavelengths and handling power of operation or other specific needs will be readily addressed. DK Photonics can respond to custom requirements with short lead times.

Applications

- Fiber laser
- Fiber amplifier
- Fiber Sensor
- Communications

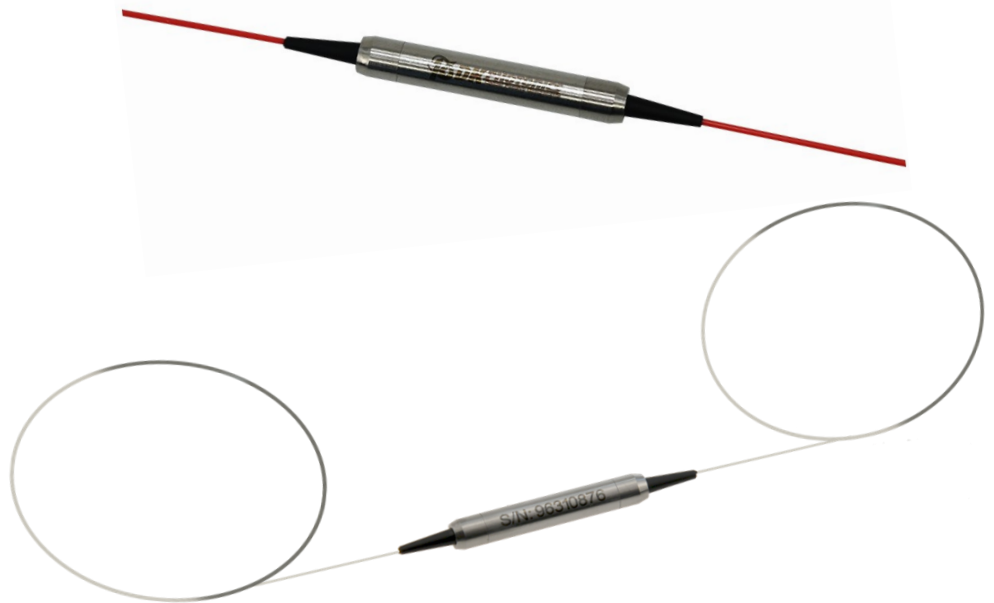

Package Dimension:

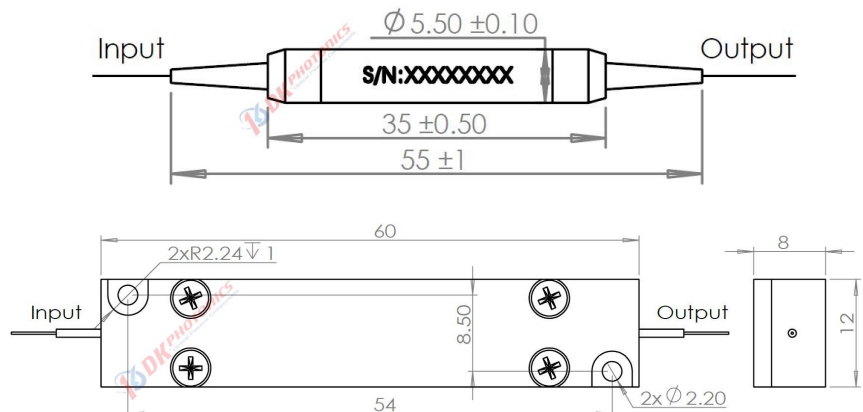

*Due to ongoing design improvements, the package size is subject to change. Please contact DK Photonics for confirmation if you have special requirements.

For more Info

Please contact us at:

Tel: +86-755-23736280

Fax: +86-755-26746512

E-mail: sales@dkphotonics.com

<https://www.dkphotonics.com>

Add.:

4F, Bldg. 18, Qinghu Industrial Park,

Dahe Road, Longhua Dis.,

Shenzhen, China 518109



1940nm Polarization Maintaining Isolator

Performance Specifications

Parameter	Unit	Values	
Operating wavelength	nm	1940	
Grade	-	P	P
Type	-	Single Stage	Dual Stage
Max. Insertion loss at 23°C ($\lambda_c \pm 20$ nm)	dB	1.2	1.5
Min. Isolation at 23°C ($\lambda_c \pm 50$ nm)	dB	16	35
Extinction ratio (Type B)	dB	≥18	
Extinction ratio (Type F)	dB	≥20	
Return loss (input/output)	dB	≥50/50	
Fiber Type	-	PM1550(default) or PM1950	
Max. Power Handling (CW)	W	0.5, 1, 2, 5, 10	
Max. Peak Power for Pulse	kW	1,5,10	
Max. Tensile Load	N	5	
Operating temperature	°C	-5°C ~ + 70°C	
Storage temperature	°C	-40°C ~ + 85 °C	
Dimensions	mm	Φ5.5× L35(<5W), 65x12x9(>5W)	

“B” for Both axis working, “F” for Fast axis blocking

1. Above specifications are for device without connector.

2. For devices with connectors, IL will be 0.3dB higher, RL will be 5dB lower and ER will be 2dB lower. The default connector key is aligned to slow axis. Power transmits through the connector less than 2W.

3. If there is pulse application, please be sure to inform us of pulse energy and peak power.

Order information P/N: PMISO-①-②-③-④-⑤-⑥-⑦-⑧

When you inquire, please provide the correct P/N number according to our ordering information and attach the appropriate description would be better. If need any connector, we do not recommend choosing a 250μm bare fiber pigtail.

①	②	③	④	⑤	⑥	⑦	⑧
Type	Wavelength	Grade	Power Handling	Axis Alignment	Pigtails Diameter	Fiber Length	Connector Type
S: Single stage	1940:1940nm	P:P Grade	L: <0.3W	B: Both axis working	25:250μm bare fiber	08:0.8m 10:1.0m	00: None FP: FC/PC
D: Dual stage	XX: Others	A: A Grade	1:1W 2:2W 5:5W 10:10W	F: Fast axis blocking	90:900μm Loose Fiber XX: Others	XX: Others	FA: FC/APC XX: Others

Part Number Example: PMISO-S-1940-P-L-F-90-10-FA

Description: 1940nm Polarization Maintaining single stage Isolator - 300mW, Fast axis blocking, PM1550 fiber, 1.0m fiber length with 0.9mm OD loose tube, and FC/APC connectors at all ports.

Ordering Information for Custom Parts

If you need to customize other specifications, please provide detailed description for your requirement.