

635nm TGG Based PM Optical Circulator

Key Features

- Low Insertion Loss
- High Isolation
- PM and Non-PM are available
- Fiber can be customized
- High Reliability
- Excellent Temperature Stability

The TGG Based Optical Circulator is a high-performance light-wave component that routes incoming signals from Port 1 to Port 2, and incoming Port 2 signals to Port 3. They're characterized with low insertion loss, high isolation, high power handling, high PER, high return loss, excellent environmental stability and reliability. They are ideal for fiber laser and instrumentation applications.

If you do not see a standard circulator that meets your needs, we welcome the opportunity to review your desired specification and quote a custom circulator. Requests for custom fiber pigtailed, different wavelengths and handling power of operation or other specific needs will be readily addressed.

Applications

- Fiber Optic Amplifiers
- Fiber Optic Laser
- Test and Measurement
- Instrumentation



Package Dimension:

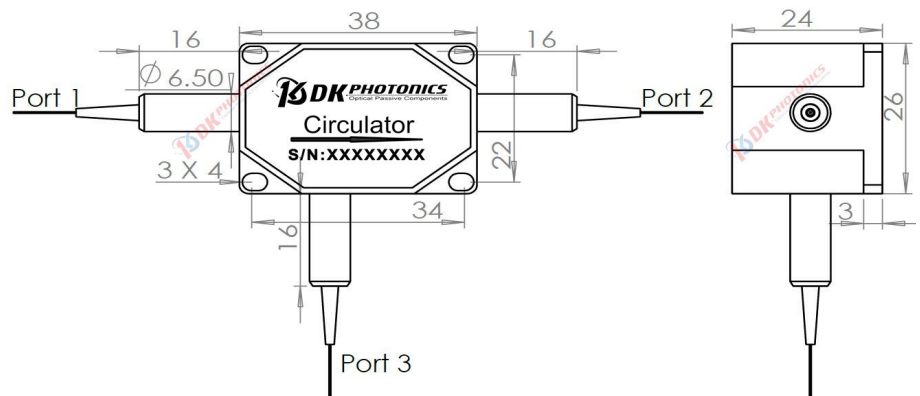

*Due to ongoing design improvements, the package size is subject to change. Please contact DK Photonics for confirmation if you have special requirements.

For more Info

Please contact us at:

Tel: +86-755-23736280

Fax: +86-755-26746512

E-mail: sales@dkphotonics.com

<https://www.dkphotonics.com>

Add.:

4F, Bldg. 18, Qinghu Industrial Park,

Dahe Road, Longhua Dis.,

Shenzhen, China 518109



635nm TGG Based PM Optical Circulator

Performance Specifications

Parameters	Unit	Values
Operation Wavelength	nm	635
Operating Wavelength Range	nm	±5
Typ. Peak Isolation	dB	25
Min. Isolation, λ_c , 23 °C	dB	20
Typ. Insertion Loss, 23 °C	dB	1.2
Max. Insertion Loss, 23 °C	dB	1.8
Min. Extinction Ratio (for PM fiber)	dB	18(Type B), 20(Type F)
Min. Cross Talk	dB	45 (Typ. 50)
Min. Return Loss	dB	45
Maximum Power Handling (continuous wave)	mW	300 mW (With Connectors or Bare Fiber), 500 mW (Spliced)
Max. Tensile Load	N	5
Fiber Type	-	PM: PM630-HP
Operating Temperature	°C	0 ~ +60
Storage Temperature	°C	-10 ~ +75

1. Above specification are for device without connector, and may change without notice.
2. IL is 1.0 dB higher and RL is 5 dB lower, ER is 2dB lower (PM type) for each connector added.
3. Type B: Both axis working, Type F: Fast axis blocked, the default is Type B if without request. (Only for PM type)

Order information

P/N: PMOC-B/F - ①-②-③-④-⑤-⑥

When you inquire, please provide the correct P/N number according to our ordering information, and attach the appropriate description would be better. If need any connector, we do not recommend choosing a 250 μ m bare fiber pigtail. For high power applications, we recommend direct splicing without connectors

①	②	③	④	⑤	⑥
Port	Operating Wavelength	Fiber Type	Fiber Diameter	Fiber Length	Connector
3:3-port	635:635nm	P63: PM630-HP	25:250 μ m bare fiber	05:0.5m	00: None
	xx: others	XX: fiber name	90:900 μ m Loose Fiber	10:1.0m	FP: FC/PC
			XX: Others	15:1.5m	FA: FC/APC
				XX: Others	XX: Others

Part Number Example: PMOC-F-3-635-P63-90-10-FA

Description: 635nm 3-port Polarization Maintaining Optical Circulator, Fast axis blocked, PM630-HP fiber, with 0.9mm OD loose tube, 1.0m length fiber pigtails, FC/APC connectors.

Ordering Information for Custom Parts

If you need to customize other specifications, please provide detailed description for your requirement.