

850nm 1x4, 1x8 PM Fiber Splitter Module (1xN)

Key Features

- Low Insertion Loss
- High Extinction Ratio
- Compact
- High Stability and Reliability

Polarization maintaining splitter/coupler modules combine multiple incoming optical fiber inputs into one output, while maintaining the polarization state of the light. It can also be used as a PM splitter.

Our PM coupler modules are assembled using thin-film filter-based 1x2 and 2x2 PM optical fiber couplers. The Polarization Maintaining Coupler is available in a wide range of coupling ratio. PM couplers are widely used in fiber optic communication systems, Raman Amplifiers and other fiber instrument applications.

If you do not see a standard PM fiber Coupler Module that meets your needs, we welcome the opportunity to review your desired specification and quote a custom PM Fiber Coupler Module. Requests for custom fiber pigtails, different coupling ratio different wavelengths and handling power of operation or other specific needs will be readily addressed.

Applications

- Fiber Optical Instrument
- Fiber amplifier
- Fiber Sensor
- Power Monitoring



Package Dimension:

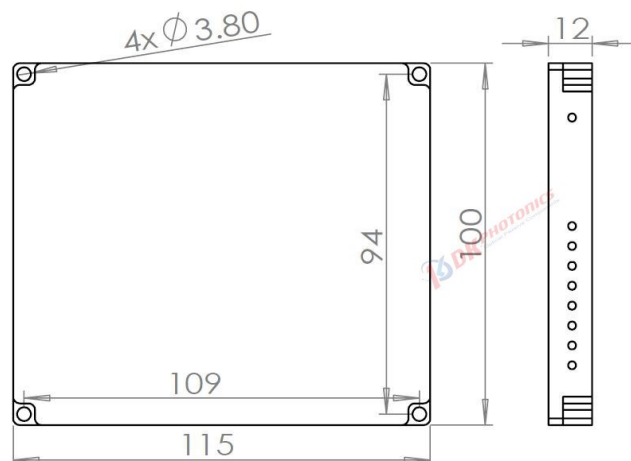

*Due to ongoing design improvements, the package size is subject to change. Please contact DK Photonics for confirmation if you have special requirements.

For more Info

Please contact us at:

Tel: +86-755-23736280

Fax: +86-755-26746512

E-mail: sales@dkphotonics.com

<https://www.dkphotonics.com>

Add.:

4F, Bldg. 18, Qinghu Industrial Park,

Dahe Road, Longhua Dis.,

Shenzhen, China 518109



850nm 1x4, 1x8 PM Fiber Splitter Module (1xN)

Performance Specifications

Parameter	Unit	Values	
Center Wavelength	nm	850	
Type	-	1X4	1X8
Operating Wavelength Range	nm	± 20	
Typ. Insertion Loss	dB	7.5	11.0
Insertion loss	dB	≤8.0	≤11.5
Uniformity	dB	≤0.8	≤1.0
Directivity	dB	≥50	≥45
Extinction ratio Type B	dB	≥20	≥18
Extinction ratio Type F	dB	≥22	≥20
Return loss (input/output)	dB	≥50	
Fiber Type	-	PM780-HP	
Operating temperature	°C	-5 ~ + 70	
Storage temperature	°C	-40 ~ + 85	
Max. Optical Power	W	0.5, 2, 5, 10	
Dimensions	mm	115x100x12(Aluminum)	

“B” for Both axis working, “F” for Fast axis blocking

- Above specifications are for device without connector. All parameters are tested at room temperature.
- Other split ratios and structures can also be customized according to requirements.
- If tap port coupling ratio is ≤ 5%, ER will be 2dB lower; for ≤1% tap port, ER is out of concern.
- For devices with connectors, IL will be 0.3dB higher, RL will be 5dB lower and ER will be 2dB lower. The default connector key is aligned to slow axis. Power transmits through the connector less than 2W.
- If there is pulse application, please be sure to inform us of pulse energy and peak power.

Order information P/N: PMFSM-①-②-③-④-⑤-⑥-⑦-⑧-⑨

When you inquire, please provide the correct P/N number according to our ordering information and attach the appropriate description would be better. If need any connector, we do not recommend choosing a 250µm bare fiber pigtail.

①	②	③	④	⑤	⑥	⑦	⑧	⑨
Type	Wavelength	Coupling Ratio	Power Handling	Axis Alignment	Fiber Type	Pigtails Diameter	Fiber Length	Connector
3:1x3	85:850nm	E: even	L:<0.5W	B: Both axis working	P78: PM780-HP	25:250µm bare fiber	08:0.8m	00: None
4:1x4	XX: Others	X: Other	1:1W	F: Fast axis blocking	XX: Others	90:900µm Loose Tube	10:1.0m	FP: FC/PC
5:1x5			3:3W			XX: Others	XX: Others	FA: FC/APC
6:1x6			5:5W					LA: LC/APC
8:1x8								XX: Others

Part Number Example : PMFSM-4-85-E-L-B-P78-90-10-FA

Description: 850nm 1x4 PM Fiber Splitter Module, 25/25/25/25 coupling ratio, 0.5W, both axis working, PM780-HP Panda fiber with 0.9mm OD loose tube, 1.0m length and FC/APC connectors at all ports.

Ordering Information for Custom Parts

If you need to customize other specifications, please provide detailed description for your requirement.